

OTC 18235

The Grane Platform

P.E. Melsom, Hydro Oil & Energy

Copyright 2006, Offshore Technology Conference

This paper was prepared for presentation at the 2006 Offshore Technology Conference held in Houston, Texas, U.S.A., 1-4 May 2006.

This paper was selected for presentation by an OTC Program Committee following review of information contained in an abstract submitted by the author(s). Contents of the paper, as presented, have not been reviewed by the Offshore Technology Conference and are subject to correction by the author(s). The material, as presented, does not necessarily reflect any position of the Offshore Technology Conference, its officers, or members. Papers presented at OTC are subject to publication review by Sponsor Society Committees of the Offshore Technology Conference. Electronic reproduction, distribution, or storage of any part of this paper for commercial purposes without the written consent of the Offshore Technology Conference is prohibited. Permission to reproduce in print is restricted to an abstract of not more than 300 words; illustrations may not be copied. The abstract must contain conspicuous acknowledgment of where and by whom the paper was presented. Write Librarian, OTC, P.O. Box 833836, Richardson, TX 75083-3836, U.S.A., fax 01-972-952-9435.

Abstract

The Grane platform is a traditional North Sea production, drilling and living-quarter platform.

The production module was a challenge during the concept period. The target was to keep it as one module in order to benefit during testing and commissioning. The result was a module of 11,200 tons, at the limit for a single-lift operation. It should also be pointed out that the weight of the module was kept within an envelope of 100 tons during the engineering period, verifying a high degree of professionalism present in the engineering organization.

I also like to mention that Aker Verdal delivered the jacket of 17,500 tons. A similar jacket was delivered for the Brage platform in 1993 with double the amount of manhours as Grane. Most of Brage's manhours were consumed outside the yard in Verdal. Effective use of experience has been a trademark of the Grane project.

Facts for the Grane platform are as follows, including the two pipelines:

- The Grane platform incorporates processing, drilling and quartering facilities
 - Dimensions
 - Water depth 127 m
 - Jacket weight 17 500 t
 - Topsides weight 22 500 t
 - Number of well slots 40
 - Living Quarters capacity 130 beds
- Two pipelines are connected to the platform
 - One 18" gas import pipeline, length 50 km, from Heimdal
 - One 28" oil export pipeline, length 210 km, to Sture terminal

Figure 1.

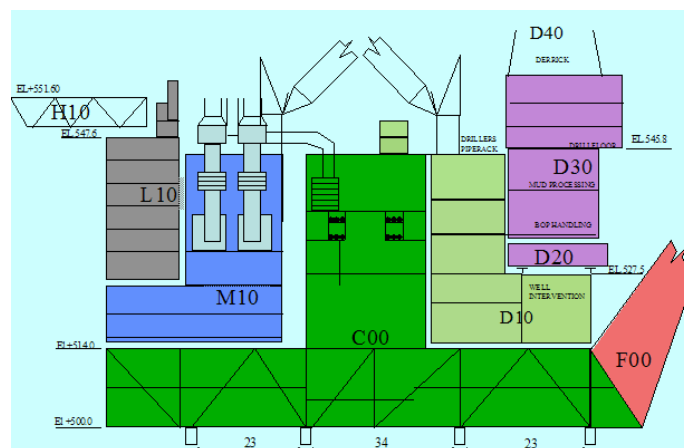

Figure 2: The schematic figure of Grane's topsides indicates the project's various EPC contracts

• Production, power generation and living quarters modules	Kværner Oil & Gas AS
• Drilling module	Aker Stord AS
• Jacket	Aker Verdal AS
• Platform installation	Heerema Marine Contractors
• Offshore hook-up	Kværner Oil & Gas AS
• Linepipe procurement	Europipe, Mitsui, Bredero Price
• Pipelines installation	European Marine Contractors
• Onshore pipeline	VJ Murphy Veidekke
• Installation work, Sture terminal	Fabricom

Figure 3: Major contracts are listed in the table. The combined total value of the contracts is NOK 8.9 billion.

Norsk Hydro had a team to follow up all these contracts. The team was organized as shown in the figure 4.